

Super Xpress Installation and Set-Up Instructions

PARTS LIST

Item	Qty	Part #	Description
1	1		Trailer
2	1	200567	Axle Assembly Complete
2A	2	200569	Axle
2B	2		Cotter Pin
2C	2	200624	Grease Seal
2D	2	200603	Castle Nut
2E	2	200604	1/2 Lug Nut
2F	2	200628	Wheel Hub
2G	4	200623	Bearing
2H	2	200597	Grease Cap
3	1	200666	Universal Pivot
4	1	200661	Tongue 39.5 Inches
5	1	200583	Tongue Bracket
6	1	200659	Tipper Latch
7	1	200585	Coupler, 2" Ball, 2 x 2 Tube
8	2	200949	Wheel
11-20	1	200634	Prepackage Hardware
11	4		7/16 x 1 Bolt
12	4		7/16 Lock Washer
13	2		7/16 x 3 Bolt
14	2		7/16 Nylon Lock Nut
15	2		3/8 x 1 Bolt
16	4		3/8 Nylon Lock Nut
17	3		3/8 x 3 Bolt
18	1		3/8 x 3 1/4 Bolt
19	4		7/16 Washer
20	2		3/8 Washer

Tools Required:

13/16 Socket
9/16 Socket and Ratchet
5/8 Socket and Ratchet
3/8 Bit
Drill
Hammer or Rubber Mallet
9/16 Wrench
5/8 Wrench

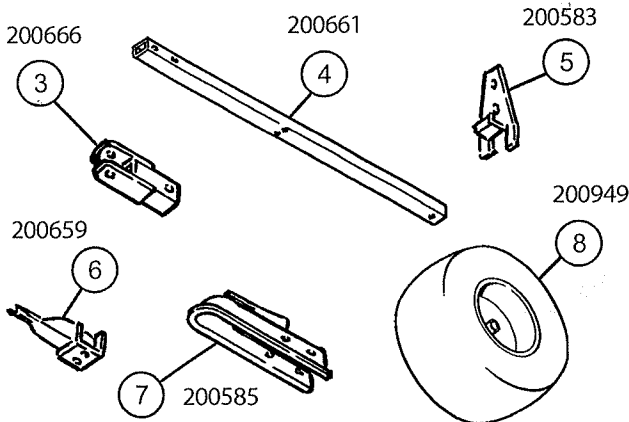
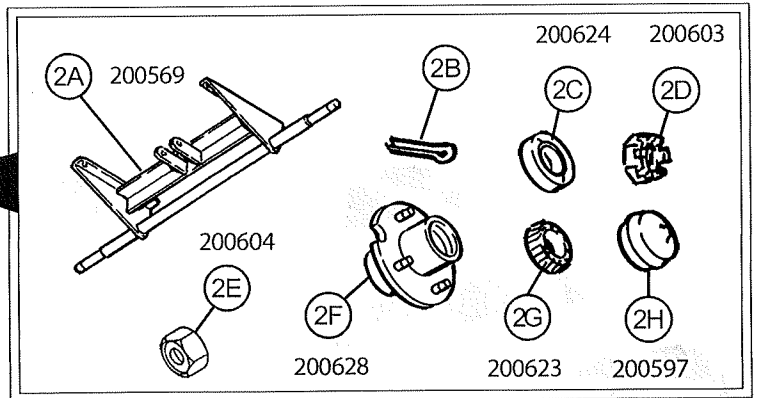
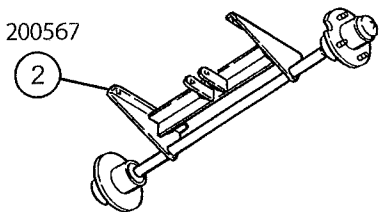
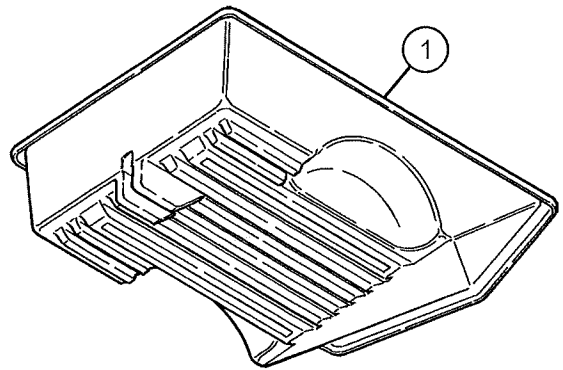

80313 - Includes Prepackage Hardware 11-20

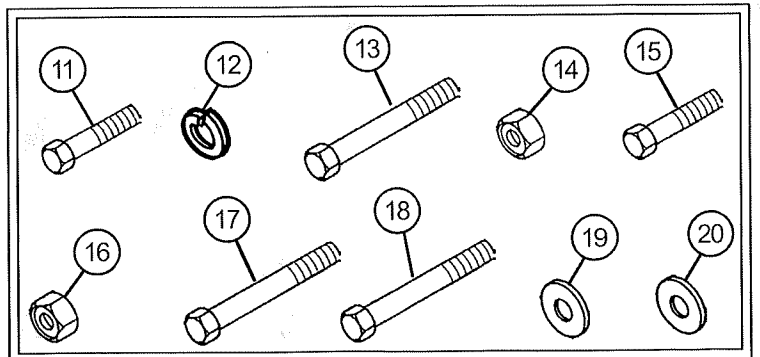

1. Attach the axle (Item 2) to the bottom side of the trailer (Item 1) with 7/16 x 1 bolts (Item 11) and 7/16 lock washers (Item 12).

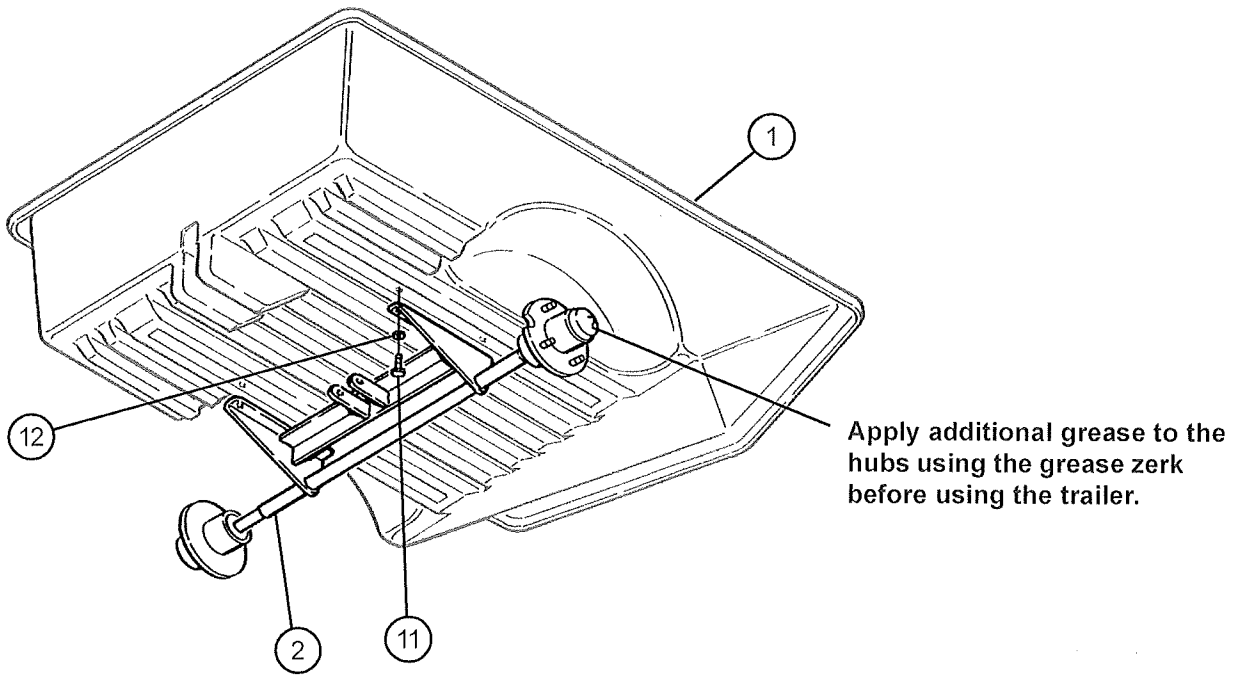

2. Attach the universal pivot (Item 3) to the axle (Item 2) with 3/8 x 3 1/4 bolt (Item 18) and 3/8 nylon lock nut (Item 16).

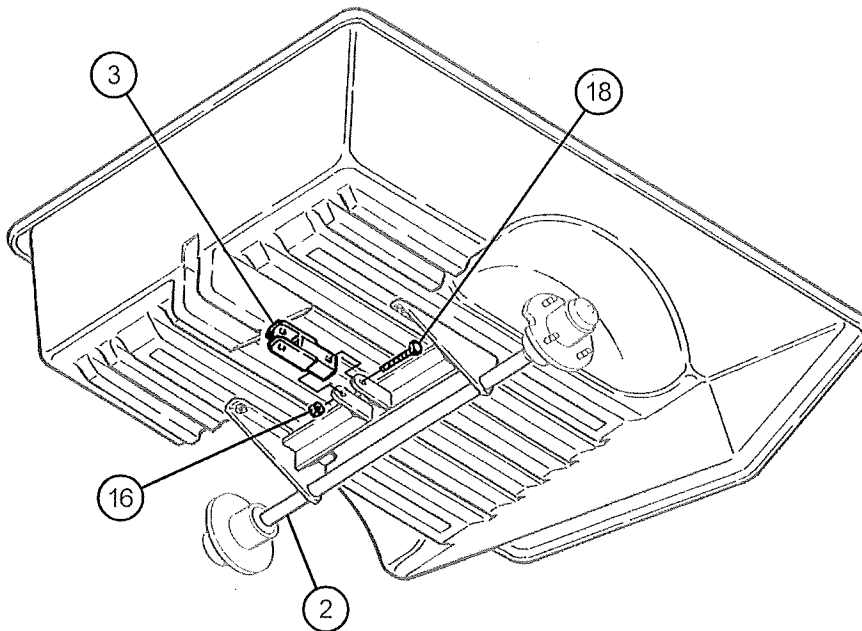

3. Attach the tongue (Item 4) to the universal pivot (Item 3) with 3/8 x 3 bolt (Item 17) and 3/8 nylon lock nut (Item 16).

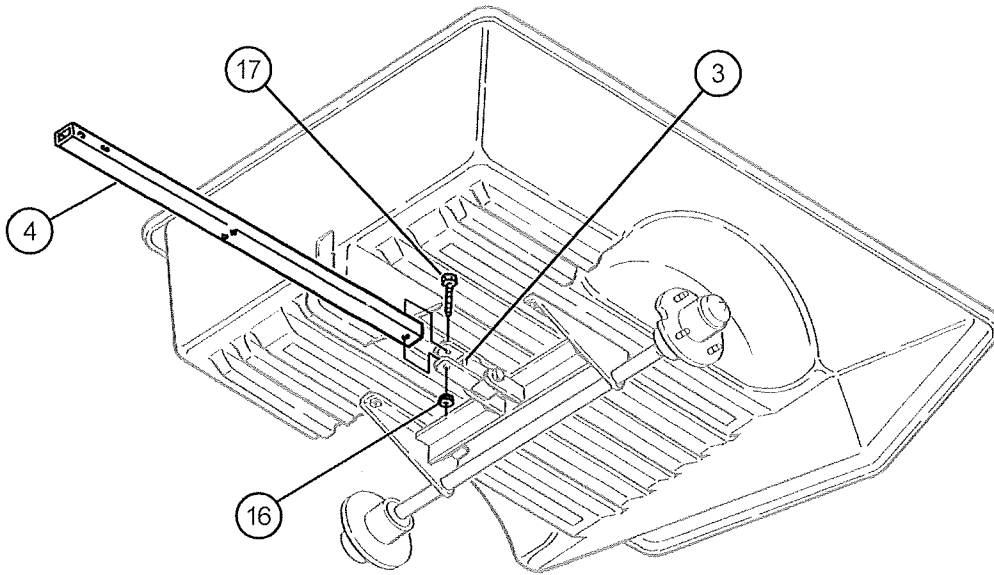

4. Attach the coupler (Item 7) to the tongue (Item 4) with 7/16 x 3 bolts (Item 13), 7/16 washer (Item 19) and 7/16 nylon lock nuts (Item 14).

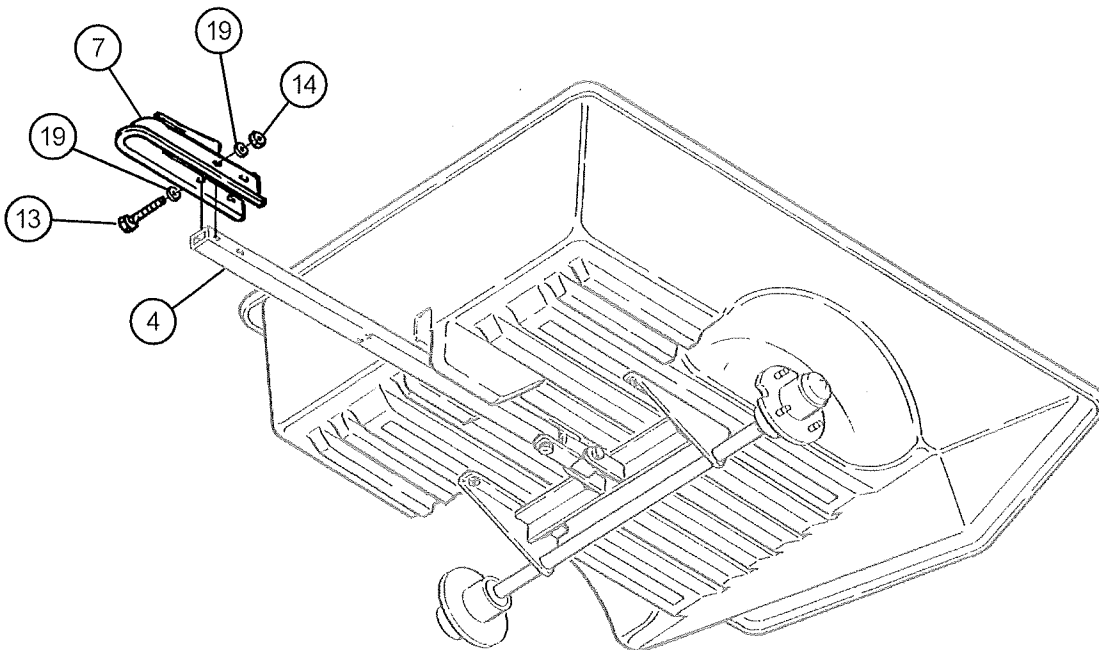

5. Attach the tipper latch (Item 6) to the tongue (Item 4) with 3/8 x 3 bolts (Item 17) and nylon lock nuts (Item 16).

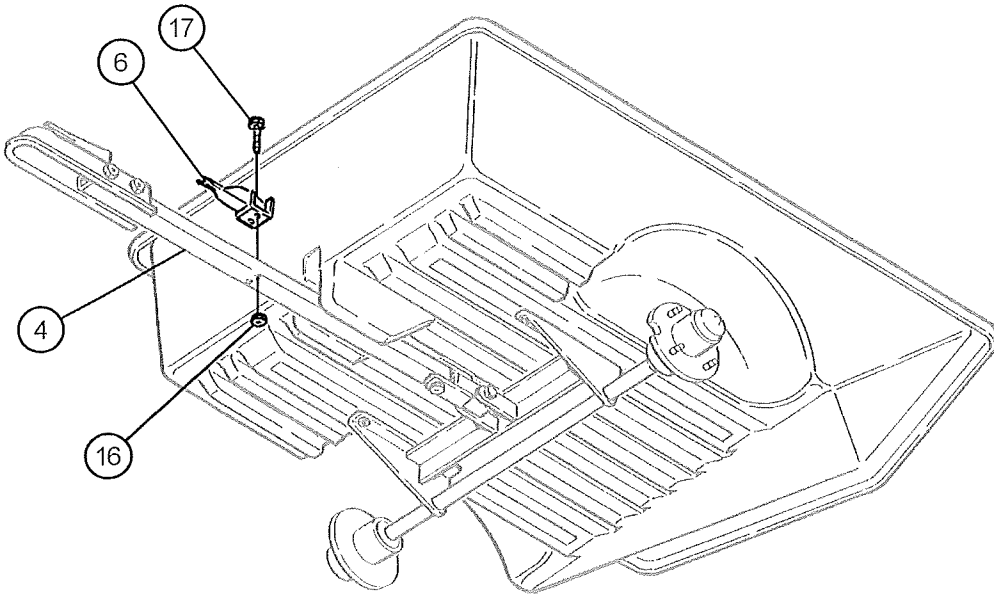

6. Attach the tongue bracket (Item 5) to the trailer (Item 1) with 3/8 x 1 bolts (Item 15), 3/8 washer (Item 20) and 3/8 nylon lock nuts (Item 16).

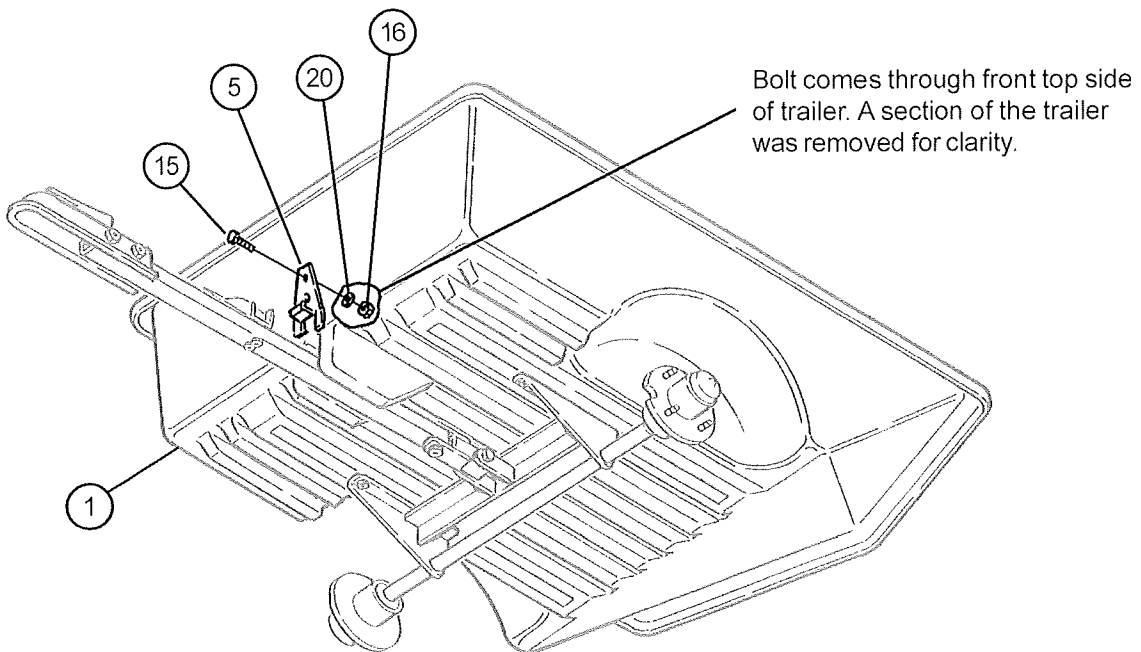

7 Assemble wheels (Item 8) to axle (Item 2) with 1/2 lug nut (Item 2E).

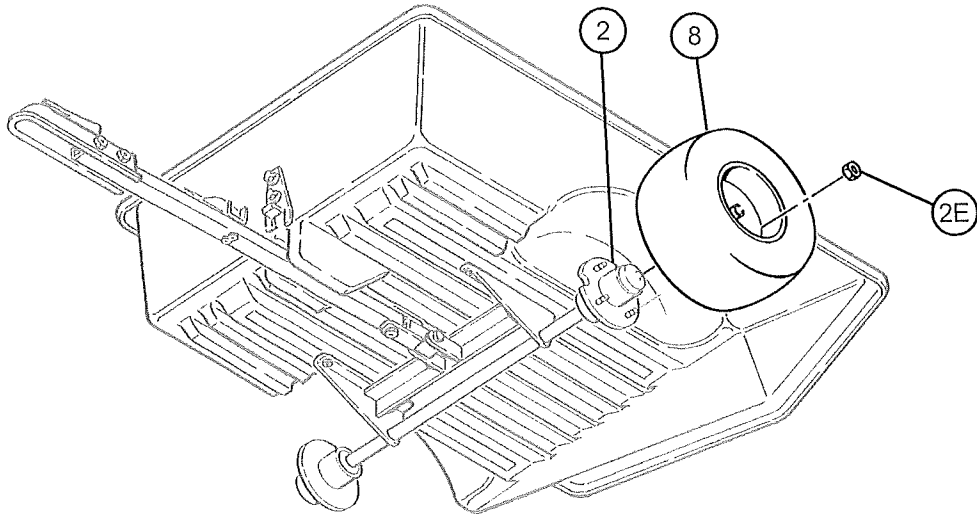

Wheel Hub Replacement Assembly Instructions

1. Slide grease seals (Item 2C) onto axle (Item 2A). Grease seal lip should face towards the bearing and hub.

Note: Grease must be applied before final assembly of seals (Item 2C). As an alternative bearings may be packed with grease by hand before assembly.

2. Slide inside bearing (Item 2G) onto axle (Item 2A). Slide wheel hub (Item 2F) onto axle (Item 2A) with bearing (Item 2G) fitting into wheel hub (Item 2F). Slide the second bearing (Item 2G) onto axle (Item 2A) and into wheel hub (Item 2F).
3. Turn castle nut (Item 2D) onto axle (Item 2A) finger tight. Push cotter pin (Item 2B) through slots in castle nut (Item 2D) and hole in axle (Item 2A). Bend cotter pin (Item 2D) over.
4. Install grease caps (Item 2H). Gently tap into place with hammer or rubber mallet. Using grease gun, apply grease until it comes through inside bearing (Item 2H). Gently tap seals (Item 2C) into place.

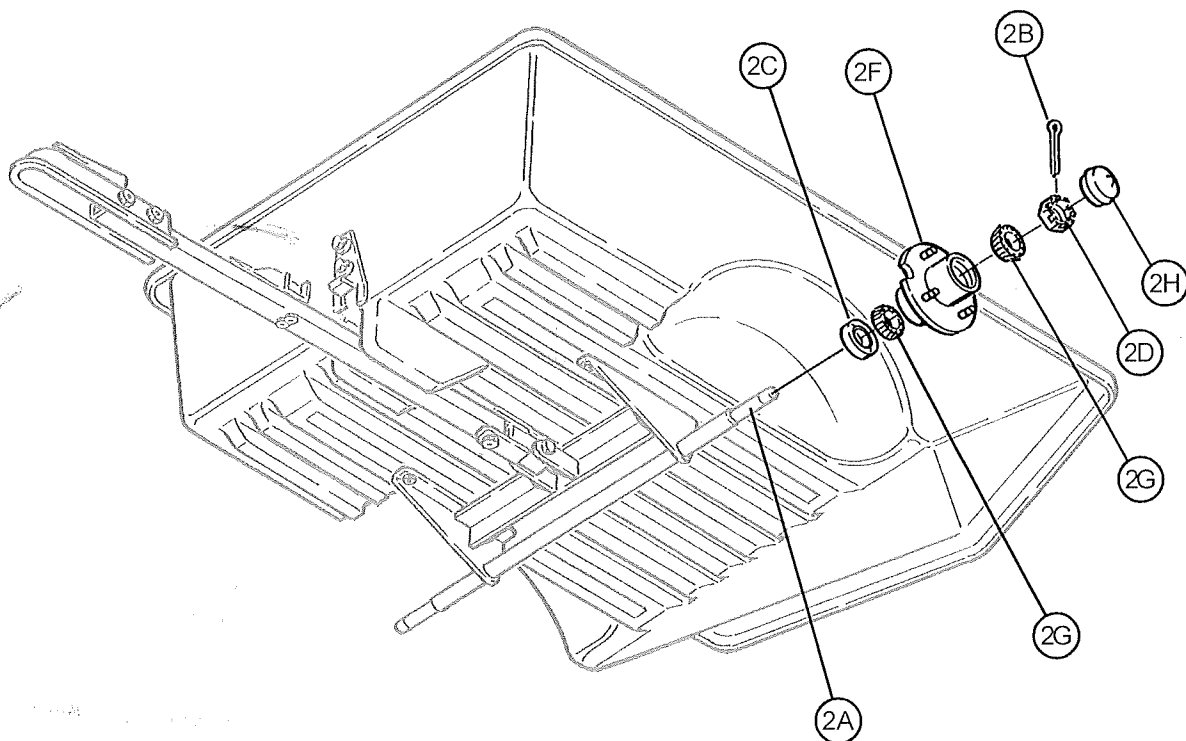

Super X ST
July, 2007

Otter Outdoors Inc.
411 W Congress St. • Maple Lake, MN 55358
Phone 320-963-6480 • www.otteroutdoors.com